

CL5800 (CL5800N: 19" LCD)

Dual Rail LCD PS/2-USB Console

- The CL5800 is a series of KVM Console modules featuring an integrated 19" LED-backlit LCD panel, a full keyboard, and a touch pad in a 1U rack-mountable sliding housing

The CL5800's LCD and keyboard/touch pad modules slide independently of each other. To maximize space in your data center, the keyboard/touch pad module slides back to "hide away" when not in use, while the thin profile LCD monitor rotates back – flush against the rack – allowing convenient monitoring of computer activity.

For added convenience, ports for an external PS/2 or USB keyboard and mouse as well as a monitor are provided on the rear panel.



Features

- Exclusive LED illumination light - designed by ATEN to illuminate the keyboard and touchpad to allow visibility in low-light conditions
- Integrated KVM console with a 19" LED-backlit LCD monitor in a dual rail housing with top and bottom clearance for smooth operation in a 1U high system rack
- Standard rack mount kit included – optional Easy Rack Mounting (single person installation) rack mount kit available (requires separate purchase)
- Supports an external console* with either PS/2 or USB connectors
- Dual interface – Supports computers and KVM switches with PS/2 or USB keyboards and mice
- Additional hot-pluggable USB mouse port on front panel (also functions as USB peripheral port)
- Internal power supply
- High video resolution:
 - Up to 1280 x 1024 @75Hz
 - Supports DDC, DDC2, DDC2B
 - DDC emulation of the LCD monitor
 - Video settings of attached computers are automatically adjusted for optimal output to the LCD monitor
- Standard 105-key keyboard; Sun keyboard emulation
- Dual rail design allows LCD monitor and keyboard/touch pad modules to operate independently
- Compatible with all ATEN KVM Switches and most other KVM switches
- Adjustable depth to fit within the rack
- Firmware upgradeable
- Supports Microsoft Intellimouse (5 keys)
- Supports Logitech and Microsoft wireless mice
- Console lock – enables the console drawer to remain securely locked away in position when not in use
- Keyboard Language supports English (US), English (UK), French, German, German (Swiss), Greek, Hungarian, Italian, Japanese, Korean, Russian, Spanish, Swedish and Traditional Chinese

* Attach a KVM extender to remotely access the computers down the hall or halfway around the world (CN8000) via the Internet.

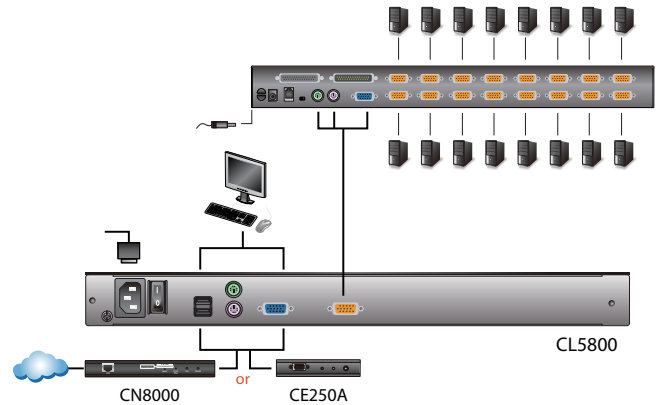
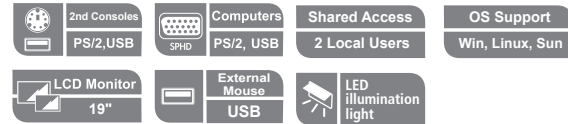

Bracket Type	Size (cm)
Standard Installation – Long	70.0 - 105.0
Easy Installation – Short	57.0 - 70.0
Easy Installation – Long	68.0 - 105.0

Specification

Function	CL5800		
Computer Connections	1		
Console Selection	Hotkey		
Connectors	External Console Keyboard	1 x 6-pin Mini-DIN Female (Purple) 1 x USB Type A Female (Black)	
	External Console Video	1 x HDB-15 Female (Blue)	
	External Console Mouse	1 x 6-pin Mini-DIN Female (Green) 1 x USB Type A Female (Black)	
	KVM Ports	1 x SPHD-18 Female (Yellow)	
USB Port	1 x USB Type A Female (Black)		
FW Upgrade	1 x RJ-11		
Power	1 x 3-prong AC Socket		
Reset	1 x Semi-recessed Pushbutton		
Switches	Power	1 x Rocker	
	FW Upgrade	1 x Slide	
	LCD Power	1 x Pushbutton	
	LCD Adjustment	4 x Pushbutton	
LEDs	Power	1 (Dark Green)	
	LCD Power	1 (Orange)	
	Lock	Num	1 (Green)
		Caps	1 (Green)
Scroll		1 (Green)	
Emulation	Keyboard / Mouse	PS/2; USB	
Video		1280 x 1024@75Hz, DDC2B	
I/P Rating		100–240VAC; 50–60Hz; 1A	
Power Consumption		120V, 22W / 230V, 24W	
Environment	Operating Temp.	0–50°C	
	Storage Temp.	-20–60°C	
	Humidity	0–80% RH Non-condensing	
Physical Properties	Housing	Metal	
	Weight	14.27 kg	
	Dimensions (L x W x H)	48.00 x 68.04 x 4.40m	

* The specifications and pictures are subject to change without notice.

